

TOUCH *feel.* LIVE



NEUHEITEN & MESSEFÜHRER 23/24

NOVELTIES & SHOW GUIDE 23/24

NOUVEAUTÉS & CATALOGUE 23/24

NIEUWS & BEURSGIDS 23/24



INHALT | CONTENT

2	PROGRAMM PROGRAMME PROGRAMME PROGRAMMA
2 - 9	FRONTEN FRONTS FAÇADES FRONTEN
10 - 11	ARBEITSPLETTEN WORKTOPS PLANS DE TRAVAIL WERKBLADEN
12 - 13	GRIFFVARIANTEN HANDLE VERSIONS VARIANTES DE POIGNEÉS GREEPVARIANTEN
14	KORPUS CARCASE CORPS CORPUS
15	TOUCH.FEEL.LIVE.
16	MESSEFÜHRER SHOW GUIDE CATALOGUE BEURSGIDS
16 - 37	ALLE AUSSTELLUNGSKÜCHEN ALL SHOW KITCHENS TOUTES LES CUISINES D'EXPOSITION ALLE SHOWROOM-KEUKENS
38	HIGHLIGHTS
40	OPEN LIVING
42	GUTE GRÜNDE GOOD REASONS DE BONNES RAISONS GOEDE REDENEN
	GRÜNDE FÜR BRIGITTE KÜCHEN REASONS TO CHOOSE BRIGITTE KÜCHEN LES RAISONS DE CHOISIR BRIGITTE KÜCHEN REDENEN OM VOOR BRIGITTE KÜCHEN TE KIEZEN
44	COLOUR CONCEPT
	AUSLAUF DISCONTINUATION FINS DE SÉRIE UITLOOP



EIN KLICK – ALLE NEUHEITEN

Wir bieten Ihnen die Möglichkeit, Fotos und Exposés zu allen Neuheiten herunterzuladen oder sie ganz einfach per Mail zu verschicken.

Scannen Sie den QR-Code zu unseren Neuheiten wie Fronten, Arbeitsplatten und Korpusdekoren oder zu jeder einzelnen Messeküche ein.



UN CLIC, TOUTES LES NOUVEAUTÉS

Nous vous offrons la possibilité de télécharger les photos et les descriptions de toutes les nouveautés, ou de les recevoir par e-mail.

Scannez le code QR pour voir nos nouveautés telles que les façades, les plans de travail, les décors des corps, ou encore toutes les cuisines présentées aux salons.



ONE CLICK - ALL NEW PRODUCTS

We invite you to download photographs and exposés of all our new products or to have them sent to you by email.

Scan the QR code to learn about our new products, including fronts, work surfaces and carcass décors, as well as we each individual show kitchen.



ÉÉN KLIK – AL HET NIEUWS

Wij bieden u de mogelijkheid foto's en informatie over alle nieuwe artikelen te downloaden of eenvoudig per e-mail te versturen.

Scan hiervoor de QR-code op onze nieuwe artikelen zoals fronten, keukenbladen en kastdecors, of op elk van onze beurskeukens.

TOUCH *feel.* LIVE

Haptische Erlebnisse im Mittelpunkt

Inmitten außergewöhnlicher Zeiten ist es von Bedeutung, dass wir neue Wege beschreiten und die Möglichkeiten der Veränderung ergreifen, die sich uns bieten. Alles befindet sich in ständiger Bewegung, viele Dinge verändern sich und es eröffnen sich neue Perspektiven. Dies hat auch Auswirkungen auf unser Zuhause. Die Küche ist längst nicht mehr nur ein Ort, an dem Mahlzeiten zubereitet werden, sondern ein Raum, den wir nutzen, um unsere Sinne zu verwöhnen und zu erleben.

Genau aus diesem Grund steht das Thema Haptik im Mittelpunkt der diesjährigen Hausmesse von Brigitte Küchen, die unter dem Motto „TOUCH.feel.LIVE“ stattfindet. Hier wird besonderes Augenmerk darauf gelegt, dass wir die Möglichkeiten der Berührung und des sinnlichen Erlebens in der Küchengestaltung erkunden und nutzen.

Focus on haptic experiences

In the midst of extraordinary times, it is important that we break new ground and seize any opportunities for change that come our way. Everything is in constant motion; much is changing, and new perspectives are opening up to us. This also has an impact on our homes. The kitchen is no longer just the place where meals are prepared, but rather a space that we use to pamper and experience our senses.

It is precisely for this reason that the subject of haptics is the focus of this year's Brigitte Küchen in-house exhibition, which is taking place under the motto of „TOUCH.feel.LIVE“. Particular attention is paid to the fact that we explore and use the possibilities of touch and sensual experience in kitchen design.

Le toucher au centre de nos réflexions

Au milieu des moments les plus marquants, il est essentiel d'explorer de nouvelles voies et de saisir les opportunités de changement. Tout est en perpétuel mouvement, le monde change et nous devons relever de nouveaux défis, ce qui ne reste pas sans conséquence pour notre maison. Les temps où la cuisine n'était qu'un lieu de travail sont révolus depuis longtemps, elle est désormais la pièce où nous éveillons nos sens et où nous vivons pleinement.

C'est une raison de plus pour inviter le toucher au Salon interne Brigitte Küchen qui aura donc cette année pour slogan : « TOUCH.feel.LIVE ». Dans ce contexte, l'attention se portera notamment sur les perceptions haptiques et sensorielles dans la cuisine.

Tastbare belevenissen staan centraal

In uitzonderlijke tijden is het belangrijk om nieuwe wegen te bewandelen en de mogelijkheden te benutten die veranderingen ons bieden. Alles is permanent in beweging, er is veel wat verandert en nieuwe mogelijkheden biedt. Dat vindt ook zijn weerslag in ons thuis. De keuken is allang niet meer alleen maar een plek waar maaltijden worden klaargemaakt - het is een ruimte geworden waarin wij alle zintuigen willen verwennen en beleven.

Dat is ook precies de reden dat het thema tastbaar centraal staat bij de huisbeurs van Brigitte Küchen dit jaar. Het motto van de huisbeurs luidt „TOUCH.feel.LIVE“. Daarbij ligt de nadruk er vooral op dat wij de mogelijkheden van aanrakingen en tastbare zintuiglijke belevenissen in het keukendesign onderzoeken en benutten.

focus on the sense

PG 1

BASE ERGO BE PURE P

DELTA

Hochwertige Melaminharzbeschichtung, ringsumlaufende Formkante
 High quality melamine resin coating, all-round contoured edge
 Mèlaminé de haute qualité, chant formé sur le pourtour
 Hoogwaardige melamineharscoating gevormde rand rondom



2155 · 4155 Schneeweiß Snow white Blanc neige Sneeuwwit	2140 · 4140 Weiß White Blanc Wit	2141 · 4141 Seidengrau Silk grey Gris soie Zijdegrijs
---	--	---



2129 · 4129 Magnolia	2148 · 4148 Kaschmir Cashmere Cachemire Kasjmier	2160 · 4160 Dust Grey
-------------------------	--	--------------------------

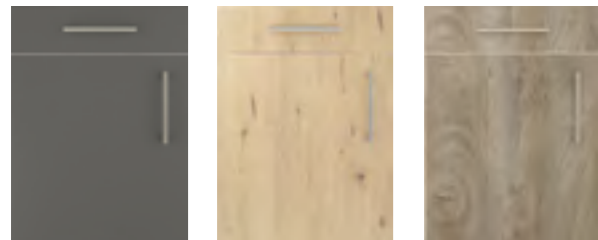

2136 · 4136 Onyxgrau Onyx grey Gris onyx Onyxgrijs	2145 · 4145 Madera Natura	2152 · 4152 Cantaro Oak
--	------------------------------	----------------------------



2111 · 4111
Astoria Eiche
Astoria Oak
Chêne Astoria
Astoria eiken

PG 1,5

BASE ERGO BE PURE P

COMO

Hochwertige Melaminharzbeschichtung, ringsumlaufende Formkante
 High quality melamine resin coating, all-round contoured edge
 Mèlaminé de haute qualité, chant formé sur le pourtour
 Hoogwaardige melamineharscoating gevormde rand rondom



2188 · 4188 Verde	2189 · 4189 Azzurro	2186 · 4186 Fichte Spruce Epicéa Vuren
----------------------	------------------------	--

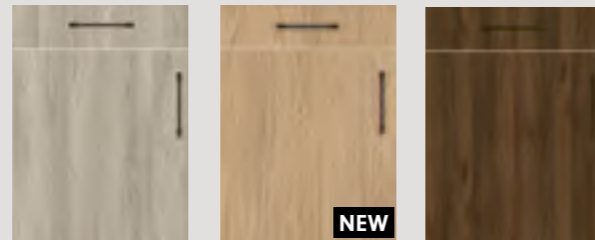

2187 · 4187 Ulme Elm Orme Olm	2184 · 4184 Eiche Oak Chêne Eiken	2185 · 4185 Nussbaum Walnut Noyer Noten
---	---	---

MONTANA

Hochwertige Melaminharzbeschichtung, ringsumlaufende Formkante,
 Maserungsverlauf vertikal
 High quality melamine resin coating, all-round contoured edge,
 Vertical direction of grain
 Mèlaminé de haute qualité, chant formé sur le poutour,
 Texture verticale
 Hoogwaardige melamineharscoating gevormde rand rondom,
 Structuurrichting verticaal



2255 · 4255 Golden Oak	2256 · 4256 Chocolate Oak
---------------------------	------------------------------

PG 1,5

BASE ERGO BE PURE P

QUADRO

Hochwertige Melaminharzbeschichtung, ringsumlaufende Formkante
 High quality melamine resin coating, all-round contoured edge
 Mèlaminé de haute qualité, chant formé sur le pourtour
 Hoogwaardige melamineharscoating gevormde rand rondom



2238 · 4238 Beton Opal Concrete opal Béton opal Beton opal	2235 · 4235 Beton Perlgrau Concrete perl grey Béton gris perle Beton parelgrijs	2237 · 4237 Beton Anthrazit Concrete anthracite Béton anthracite Beton antraciet
--	---	--

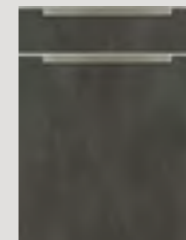

2239 · 4239
Beton Schwarz
Concrete black
Béton noir
Beton zwart

HAVANNA

Hochwertige Melaminharzbeschichtung, ringsumlaufende Formkante,
 Maserungsverlauf horizontal
 High quality melamine resin coating, all-round contoured edge,
 Horizontal direction of grain
 Mèlaminé de haute qualité, chant formé sur le poutour,
 Texture horizontale
 Hoogwaardige melamineharscoating gevormde rand rondom,
 Structuurrichting horizontaal



2281 · 4281 Golden Oak	2282 · 4282 Chocolate Oak
---------------------------	------------------------------

PG 1,5

BASE ERGO BE PURE P

SENSE

PerfectSense®

Hochwertige UV-Mehrschichtlackierung, Mattlack, ringsumlaufende Formkante
 High-quality UV multi-layer lacquer finish, matt laquer, all-round contoured edge
 Laqué multicouches UV de haute qualité, Laqué mat, chant formé sur le pourtour
 Hoogwaardige meerlaagse UV-laklaag, Matlak, gevormde rand rondom



2230 · 4230 Weiß White Blanc Wit	2231 · 4231 Seidengrau Silk grey Gris soie Zijdegrijs	2232 · 4232 Kaschmir Cashmere Cachemire Kasjmier
--	---	--



2233 · 4233 Fossil	2234 · 4234 Graphite
-----------------------	-------------------------



Anti-Fingerprint
 Anti-fingerprint
 Anti-empainte
 Anti-vingerafdruk

PG 2

BASE ERGO PURE BEP

LOFT

Hochwertige Mehrschichtlackierung, Mattlack, ringsumlaufende Formkante
 High-quality multi-layer lacquer finish, matt laquer, all-round contoured edge
 Laqué multicouches de haute qualité, Laqué mat, chant formé sur le pourtour
 Hoogwaardige meerlaagse laklaag, Matlak, gevormde rand rondom



2220 · 4220
Schneeweiß
Snow white
Blanc neige
Sneeuw wit

2221 · 4221
Seidengrau
Silk grey
Gris soie
Zijdegrijs

2222 · 4222
Magnolia



2225 · 4225
Kaschmir
Cashmere
Cachemire
Kasjmier

2224 · 4224
Dust Grey

2223 · 4223
Dark Black

Anti-Fingerprint
 Anti-fingerprint
 Anti-empainte
 Anti-vingerafdruk

PG 2

BASE ERGO PURE BEP

FRESH

Hochwertige Mehrschichtlackierung, Hochglanz lackiert, ringsumlaufende Formkante
 High-quality multi-layer lacquer finish, High-gloss lacquered, all-round contoured edge
 Laqué multicouches de haute qualité, Laqué brillant, chant formé sur le pourtour
 Hoogwaardige meerlaagse laklaag, Hoogglanslak, gevormde rand rondom

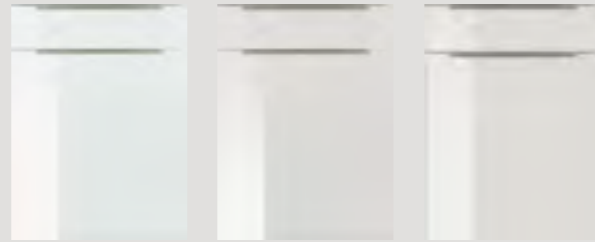

2317 · 4317
Schneeweiß
Snow white
Blanc neige
Sneeuw wit

2312 · 4312
Weiß
White
Blanc
Wit

2316 · 4316
Seidengrau
Silk grey
Gris soie
Zijdegrijs



2313 · 4313
Magnolia

2314 · 4314
Kaschmir
Cashmere
Cachemire
Kasjmier

PG 3

BASE ERGO PURE BEP

CALAS

Hochwertige Mehrschichtlackierung, Mattlack, umlaufend mit gerundeten Kanten
 High-quality multi-layer lacquer finish, matt laquer, rounded edges on all sides
 Laqué multicouches de haute qualité, Laqué mat, chants arrondis sur le pourtour
 Hoogwaardige meerlaagse laklaag, Matlak, rondom met afgeronde kanten



2382 · 4382
Weiß
White
Blanc
Wit

2387 · 4387
Seidengrau
Silk grey
Gris soie
Zijdegrijs

2383 · 4383
Magnolia



2385 · 4385
Kaschmir
Cashmere
Cachemire
Kasjmier

PG 3

BASE ERGO PURE BEP

CRISTAL

Hochwertige PUR-Mehrschichtlackierung, Hochglanz lackiert, umlaufend mit gerundeten Kanten
 High quality PUR multiple layer lacquering, High-gloss lacquered, rounded edges on all sides
 Laqué multicouches PUR de haute qualité, Laqué brillant, chants verticaux et horizontaux arrondis
 Hoogwaardige meerlaagse PUR-laklaag, Hoogglanslak, rondom met afgeronde kanten



2444 · 4444
Weiß
White
Blanc
Wit

2446 · 4446
Seidengrau
Silk grey
Gris soie
Zijdegrijs

2445 · 4445
Magnolia

OXFORD

Hochwertige Melaminharzbeschichtung, ringsumlaufende Formkante
 High quality melamine resin coating, all-round contoured edge
 Mèlaminé de haute qualité, chant formé sur le pourtour
 Hoogwaardige melamineharscoating, gevormde rand rondom

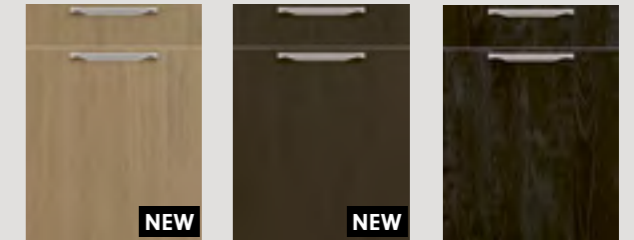

2336 · 4336
Masteroak Fumed

2337 · 4337
Masteroak Brown

2335 · 4335
Sherwood Nero

PG 3

BASE B ERGO E

LORRAINE

Matt lackiert, moderne Kassettenfront, kombinierbar mit Normandie
 Matt lacquer, modern cofferred front, combinable with Normandie
 Laqué mat, façade à encadrement droit moderne, à combiner avec Normandie
 Matlak, moderne cassettefront, te combineren met Normandie



2457
 Weiß
 White
 Blanc
 Wit

PG 3

BASE B ERGO PURE P

YUKON

Matt lackiert, moderne Rahmenfront, kombinierbar mit Piemont
 Matt lacquer, modern frame finish, combinable with Piemont
 Laqué mat, cadre de façade moderne, à combiner avec Piemont
 Matlak, moderne raamwerkuitvoering, te combineren met Piemont

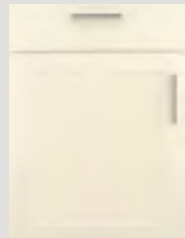

2386 · 4386
 Magnolia



Sonderlackierung (9999) in Struktursamtlack (LA);
 RAL- oder NCS-Farbtöne frei wählbar
 Special lacquering (9999) in textured velvet lacquer (LA);
 free choice of RAL or NCS shades
 Laque spéciale (9999) laqué velours structuré (LA);
 nuanciers RAL ou NCS au choix
 Speciale laklaag (9999) van gestructureerde fluweellak (LA);
 RAL- of NCS-kleuren naar keuze



Standardlackierung in Struktursamtlack (LA);
 It. Farbvarianten-Übersicht
 Standard lacquering in textured velvet lacquer (LA);
 as per the table of colour options
 Laque standart en structure velour laquée (LA);
 aperçu choix de couleurs
 Standaard laklaag van gestructureerde fluweellak (LA);
 vigs. overzicht kleurenvarianten

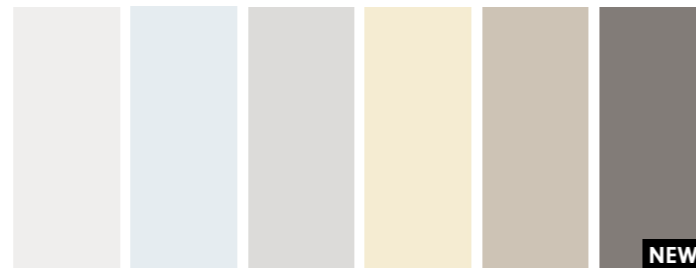

77	215	218	79	202	248
Verkehrsweiß	Schneeweiß	Seidengrau	Magnolia	Kaschmir	Fossil
Traffic white	Snow white	Silk grey		Cashmere	
Blanc trafic	Blanc neige	Gris soie		Cachemire	
Verkeerswit	Sneeuw wit	Zijdegrijs		Kasjmier	



236	245	247	246	216	249
Vintage Green	Salbei	Olive	Dust Grey	Onyxgrau	Volcano
	Sage			Onyx grey	
	Sauge			Gris onyx	
	Salie			Onyxgrijs	



228	250	242
Stahlblau	Graphite	Dark Black
Steel blue		
Bleu acier		
Staalblauw		

PG 4

BASE B ERGO E

NORMANDIE

Struktursamtlack, moderne Kassettenfront, kombinierbar mit Lorraine
 Textured velvet lacquer, modern cofferred front, combinable with Lorraine
 Laqué velours structuré, façade à encadrement droit moderne, à combiner avec Lorraine
 Gestructureerde fluweellak, moderne cassettefront, te combineren met Lorraine



3470-



PG 4

BASE B ERGO PURE P

PIEMONT

Struktursamtlack, moderne Rahmenfront, kombinierbar mit Yukon
 Textured velvet lacquer, modern frame finish, combinable with Yukon
 Laqué velours structuré, cadre de façade moderne, à combiner avec Yukon
 Gestructureerde fluweellak, moderne raamwerkuitvoering, te combineren met Yukon



3460-
 4460-



SINUS

Struktursamtlack, ringsumlaufend farbig lackiert
 Textured velvet lacquer, coloured lacquered on all sides
 Laqué velours structuré, laqué couleur sur le pourtour
 Gestructureerde fluweellak, rondom in gekleurde lak



3000-
 4000-



PG 4

BASE B ERGO PURE P

AROSA

Hochwertiger Schichtstoff, samtmatt, ringsumlaufende Formkante
 High-quality laminate, velvet matt, all-round contoured edge
 Stratifié de haute qualité, mat satiné, chant formé sur le pourtour
 Hoogwaardig laminaat, Fluweelmat, gevormde rand rondom



2295 · 4295
 Fenix Bianco



2296 · 4296
 Fenix Grigio Londra



2294 · 4294
 Fenix Nero

PG 5

BASE B ERGO PURE P

NOVA

Hochwertige Glaslaminat-Beschichtung, hochglänzend,
 ringsumlaufende Formkante
 High-quality glass laminate coating, high-gloss,
 all-round contoured edge
 Revêtement en verre feuilleté de haute qualité, hautement brillant,
 chant formé sur le pourtour
 Hoogwaardige glaslaminaat-coating, Hoogglans,
 gevormde rand rondom



2394 · 4394
 Neve High Gloss



2398 · 4398
 Bianco High Gloss



2396 · 4396
 Sabbia High Gloss

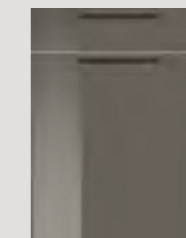

2395 · 4395
 Titanio High Gloss



2397 · 4397
 Piano High Gloss



Anti-Fingerprint
 Anti-fingerprint
 Anti-empainte
 Anti-vingerdruk

PG 5

BASE **B** ERGO **E** PURE **P**

NEW YORK

Hochwertige Metall-Effekt-Lackierung, umlaufend mit gerundeten Kanten
 High-quality metal effect lacquering, rounded edges on all sides
 Laqué effet métallique, chants arrondis sur le pourtour
 Laklaag met metaaleffect, rondom met afgeronde randen



2630-700 · 4630-700 Industrial Grey
 2630-702 · 4630-702 Industrial Copper

PORTO

Hochwertige Glaslaminat-Beschichtung, matt, ringsumlaufende Formkante
 High-quality glass laminate coating, matt, all-round contoured edge
 Revêtement en verre feuilleté de haute qualité, mat, chant formé sur le pourtour
 Hoogwaardige glaslaminaat-coating, mat, gevormde rand rondom



2261 · 4261 Neve Matt
 2267 · 4267 Bianco Matt
 2263 · 4263 Sabbia Matt



2262 · 4262 Titanio Matt
 2266 · 4266 Graphite Matt
 2264 · 4264 Piano Matt

Anti-Fingerprint
 Anti-fingerprint
 Anti-empainte
 Anti-vingerafdruk

PG 5

BASE **B** ERGO **E** PURE **P**

FLORIDA MULTICOLOUR

Hochwertige PUR-Mehrschichtlackierung, Mattlack, umlaufend mit gerundeten Kanten
 High-quality PUR multiple layer lacquering, matt laquer, rounded edges on all sides
 Laqué multicouches PUR de haute qualité, laqué mat, chants arrondis sur le pourtour
 Hoogwaardige meerlaagse PUR-laklaag, matlak, rondom met afgeronde randen

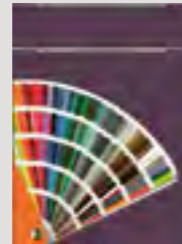

RAL
 NCS

Sonderlackierungen (950) in Mattlack (ML); RAL- oder NCS-Farbtöne frei wählbar
 Special lacquering (950) in matt laquer (ML); free choice of RAL or NCS shades
 Laque spéciale (950) en laqué mat (ML); nuanciers RAL ou NCS au choix
 Speciale laklaag (950) van matlak (ML); RAL- of NCS-kleuren naar keuze

2100-950
 4100-950

PG 6

BASE **B** ERGO **E** PURE **P**

CALIFORNIA MULTICOLOUR

Hochwertige PUR-Mehrschichtlackierung, Hochglanz lackiert, umlaufend mit gerundeten Kanten
 High-quality PUR multiple layer lacquering, high-gloss lacquered, rounded edges on all sides
 Laqué multicouches PUR de haute qualité, en laqué brillant, chants arrondis sur le pourtour
 Hoogwaardige meerlaagse PUR-laklaag, hoogglanzend gelakt, rondom met afgeronde randen



RAL
 NCS

Sonderlackierungen (980) in Hochglanzlack (HL); RAL- oder NCS-Farbtöne frei wählbar
 Special lacquering (980) in high gloss laquer (HL); free choice of RAL or NCS shades
 Laque spéciale (980) en laqué brillant (HL); nuanciers RAL ou NCS au choix
 Speciale laklaag (980) van hoogglanslak (HL); RAL- of NCS-kleuren naar keuze

2200-980
 4200-980

PG 9

BASE **B** ERGO **E** PURE **P**

WALLIS

Dickfurnier | Echtholz furniert, Mehrschichtlackierung, Furnierkante
 Thick veneer | Real wood veneer, Multiple layer lacquering, Veneered edging
 Placage épais | Placage bois véritable, laqué multicouches, chant plaqué
 Dik fineer | echt houtfi neer, Meerlaagse laklaag, Gefineerde rand



2700-322 · 4700-322 Hell
 2700-321 · 4700-321 Clair
 2700-324 · 4700-324 Licht
 2700-321 · 4700-321 Natur
 2700-324 · 4700-324 Burned Oak



2700-325 · 4700-325 Schwarz
 Black
 Noir
 Zwart

PG 9

BASE **B** ERGO **E** PURE **P**

BERN

Dickfurnier | Echtholz furniert, Mehrschichtlackierung, Furnierkante | Rahmen Massiv
 Thick veneer | Real wood veneer, Multiple layer lacquering, Veneered edging | Solid frame
 Placage épais | Placage bois véritable, laqué multicouches, chant plaqué | cadre massif
 Dik fineer | echt houtfi neer, Meerlaagse laklaag, Gefineerde rand | Raamwerk massief

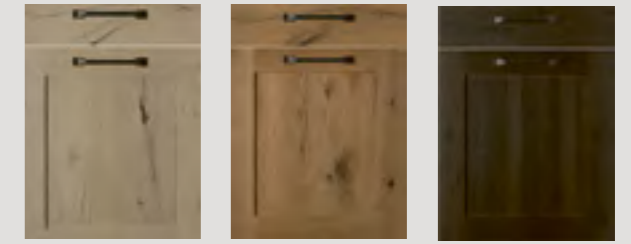

2800-322 Hell
 2800-321 Clair
 2800-324 Licht
 2800-321 Natur
 2800-324 Burned Oak



2800-325 Schwarz
 Black
 Noir
 Zwart

ARBEITSPLETTEN | WORKTOPS | PLANS DE TRAVAIL | WERKBLADEN

Dekorgruppe 1 | Decor group 1 | Catégorie de décor 1 | Decorgroep 1

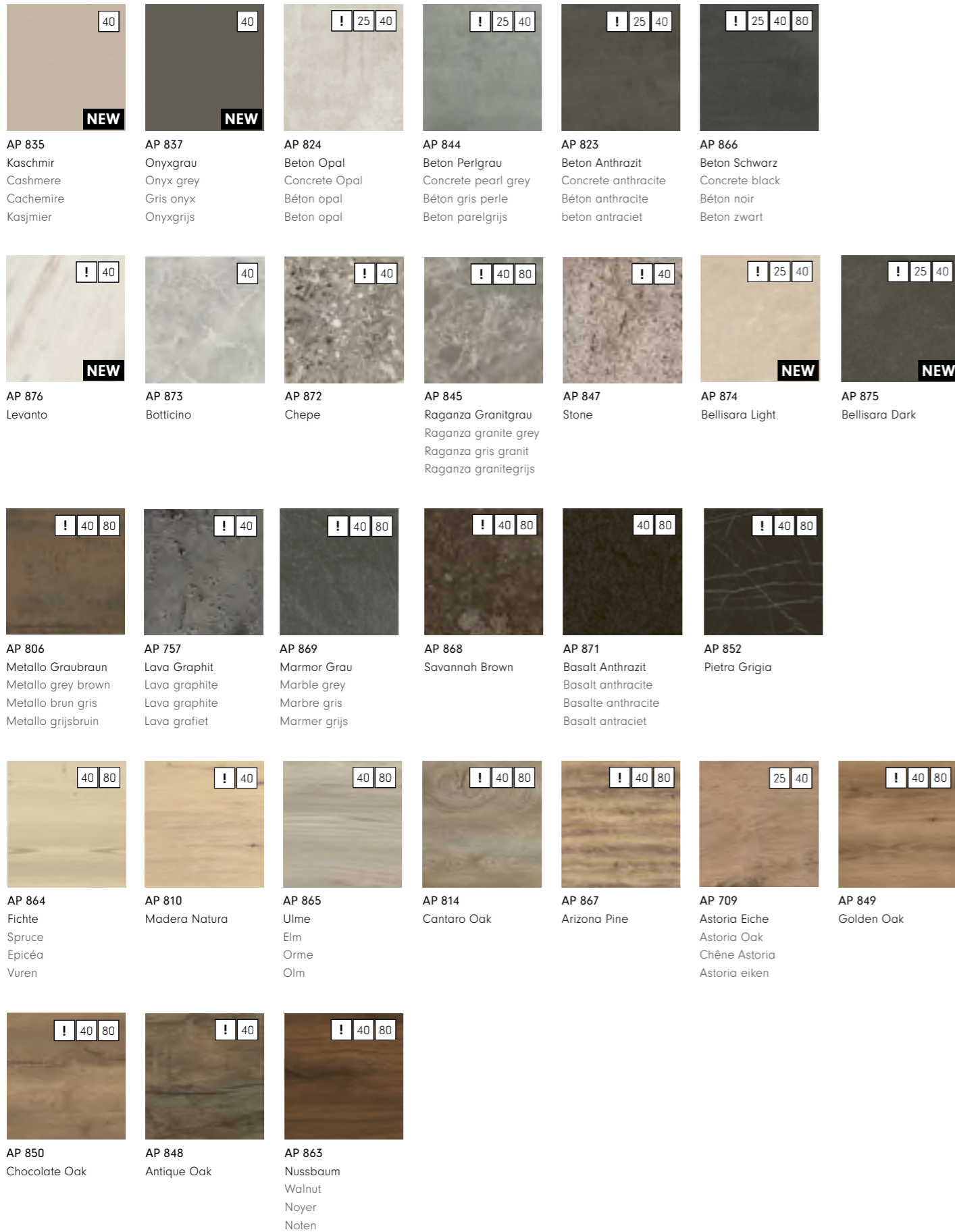

Dekorgruppe 2 | Decor group 2 | Catégorie de décor 2 | Decorgroep 2

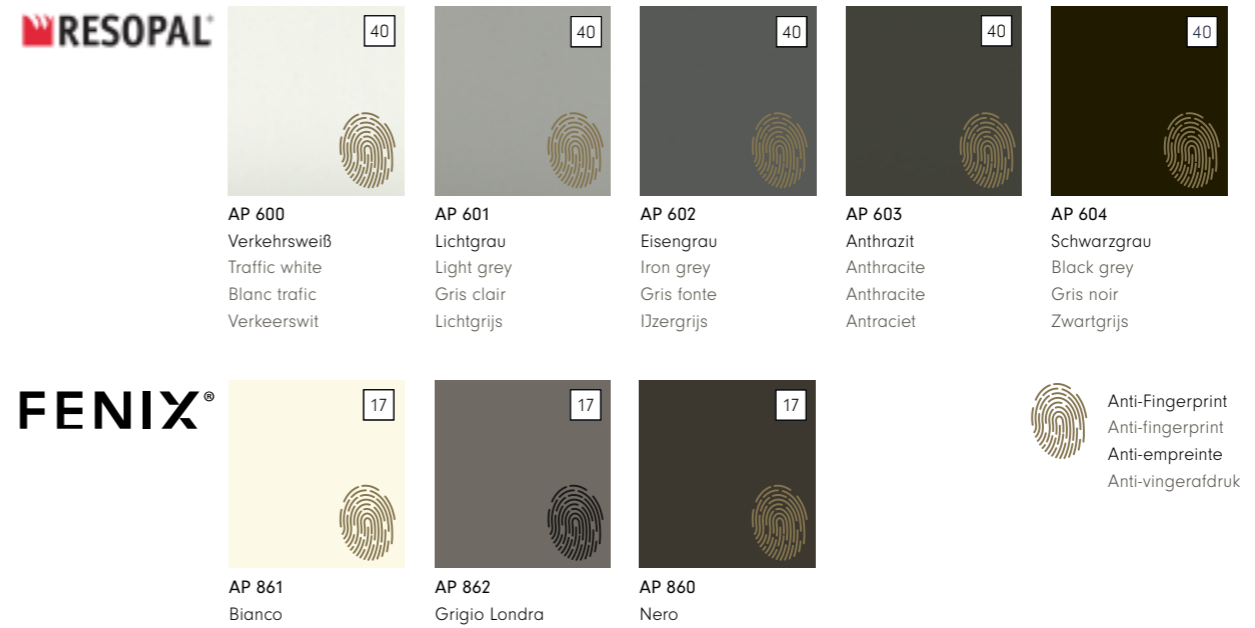

17 Arbeitsplatten 17 mm | worktops 17 mm
Plans de travail 17 mm | Werkbladen 17 mm



25 Arbeitsplatten 25 mm | worktops 25 mm
Plans de travail 25 mm | Werkbladen 25 mm

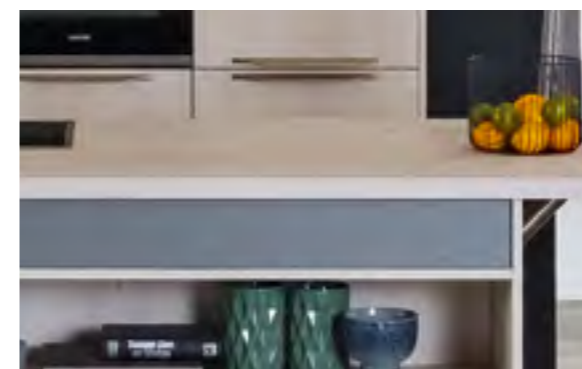

40 Arbeitsplatten 40 mm | worktops 40 mm
Plans de travail 40 mm | Werkbladen 40 mm

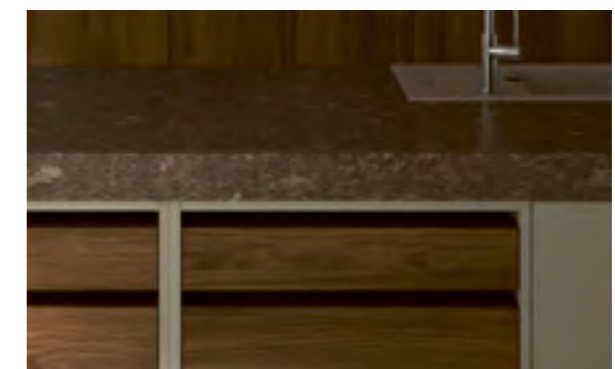

80 Arbeitsplatten 80 mm | worktops 80 mm
Plans de travail 80 mm | Werkbladen 80 mm

! Großformatiges Dekorbild | large-format decor image
Grand format avec nuances | Groot motief

GRIFFVARIANTEN | HANDLE VERSIONS | VARIANTES DE POIGNEÉS | GREEPVARIANTEN

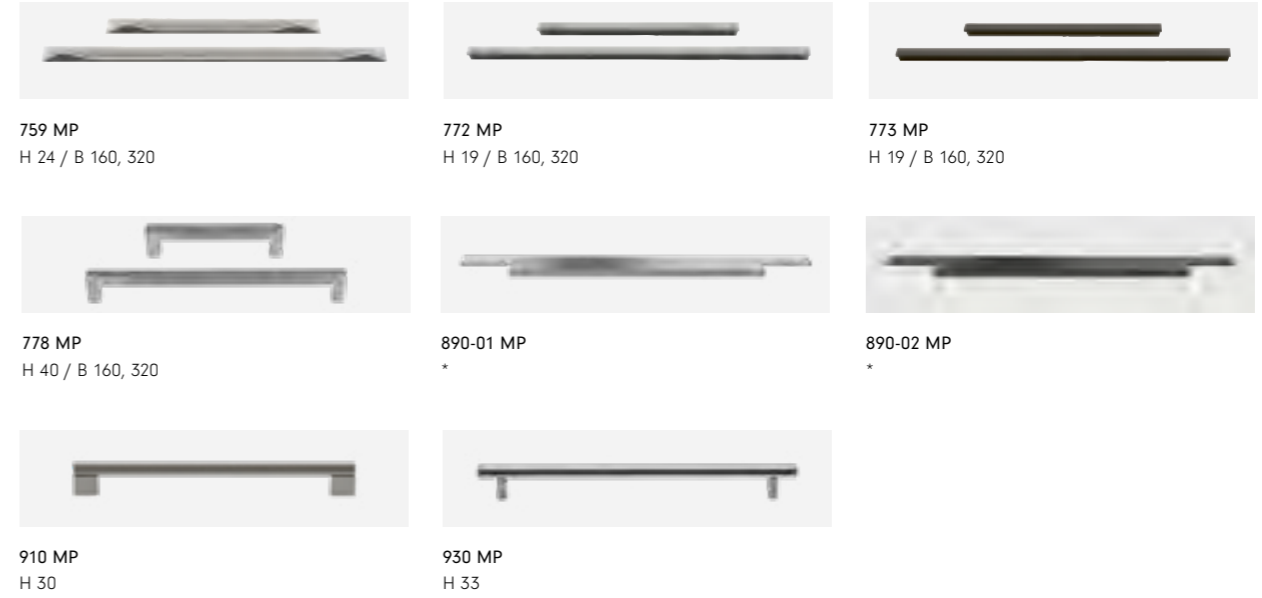
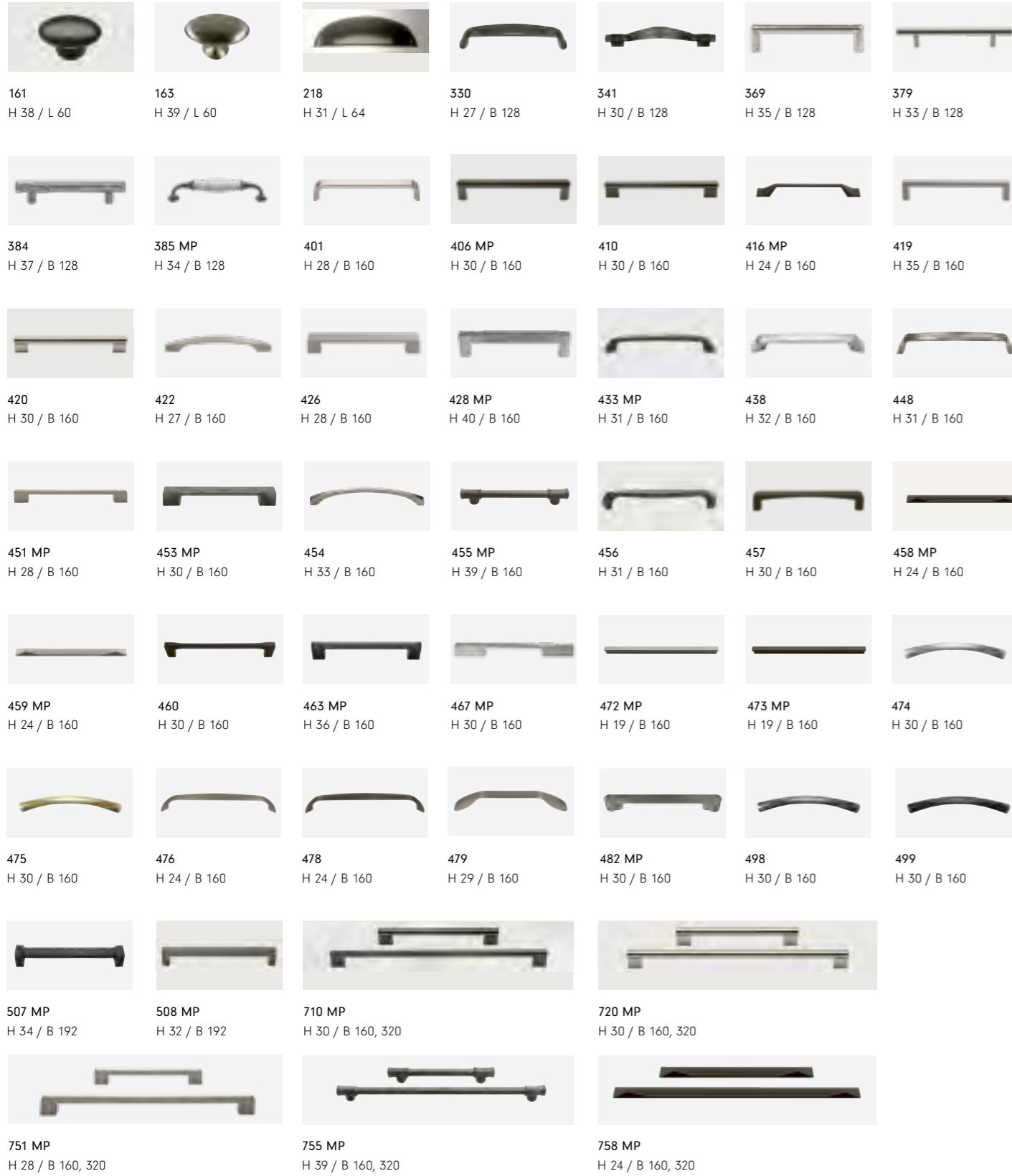

GRIFFMULDENPROFIL ELOXIERT + PULVERBESCHICHTET* | ANODISED, RECESSED GRIP PROFILE + POWDER-COATED* PROFIL DE CREUX DE POIGNÉE ANODISÉ + FINITION ÉPOXY* | GEANODISEERDE KOMGREEP + MET POEDERCOATING*



GRIFFMULDENPROFIL STRUKTUERSAMTLACK | RECESSED GRIP PROFILE TEXTURED VELVET LACQUER PROFIL DE CREUX DE POIGNÉE LAQUÉ VELOURS STRUCTURÉ | KOMGREEP STRUCTUURZIJDELAK



GRIFFMULDENPROFIL MATTLACK | RECESSED GRIP PROFILE MATT LACQUER PROFIL DE CREUX DE POIGNÉE LAQUÉ MAT | KOMGREEP MATLAK

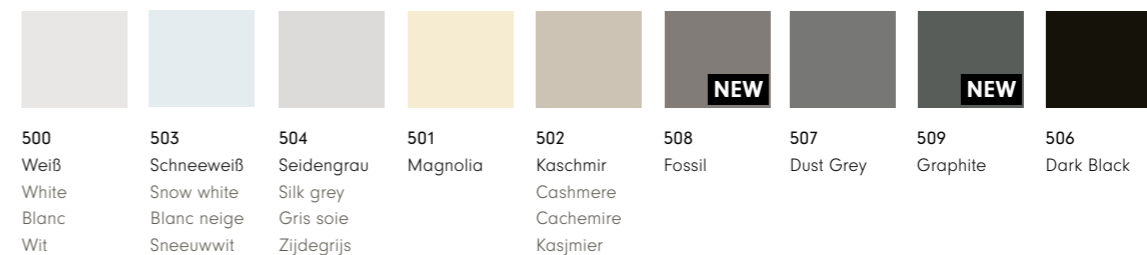

H = Höhe in mm | handle height in mm | Hauteur en mm | GREEPHOOGTE in mm
B = Bohrabstand in mm | hole spacing in mm | Entraxe en mm | BOORAFSTAND in mm

* = Griffleiste | Grip ledge | Poignée profilée | GREEPLIJST
MP = gegen Mehrpreis | for an extra charge | supplém. de prix | Tegen meerprijs



108 Schneeweiß
Snow white
Blanc neige
Sneuwit

109 Seidengrau
Silky grey
Gris soie
Zijdegrijs

29 Magnolia

104 Kaschmir
Cashmere
Cachemire
Kasjmier



110 Madera Natura

114 Cantaro Oak

82 Astoria Eiche
Astoria Oak
Chêne Astoria
Astoria eiken

119 Golden Oak

120 Chocolate Oak

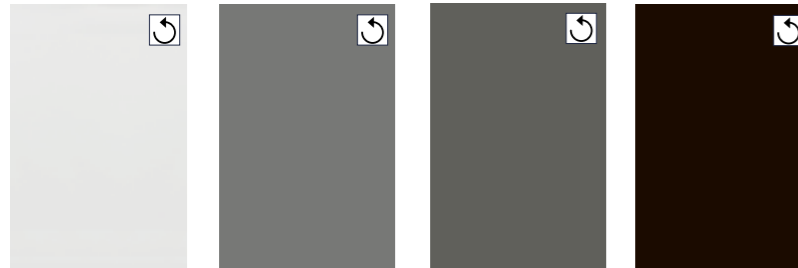

04 Weiß
White
Blanc
Wit

124 Dust Grey

123 Onyxgrau
Onyx grey
Gris onyx
Onyxgrijs

122 Dark Black

Zu weiteren Farben und Umfeldgestaltungen wenden Sie sich bitte an Ihren Fachhändler.
For additional colours and surrounding designs, please contact your specialist supplier.
Pour plus d'informations sur les autres couleurs et concepts, veuillez vous adresser à votre vendeur spécialisé.
Voor meer kleuren en vormgevingmogelijkheden kunt u contact opnemen met uw vakhandel.

Dekor beidseitig | Decor on both sides | Décoration sur les deux côtés | Dubbelzijdig decor



TOUCH
feel.
LIVE

Haptische Erlebnisse in den Programmen:
Haptic experiences in the ranges:
Perceptions haptiques dans les programmes :
Tastbare belevenissen in de programma's:

SENSE

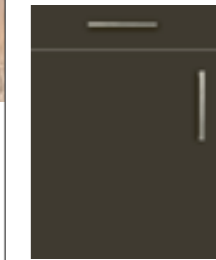

LOFT



COMO



OXFORD

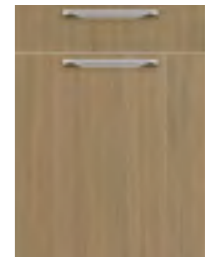

AROSA

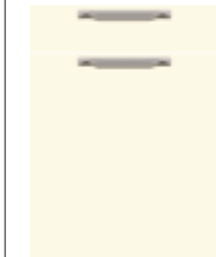

PORTO



Oberflächen (er-)leben

In einer Welt, die stark von digitalen Einflüssen geprägt ist, gewinnt Haptik eine immer größere Bedeutung. Neue Eiche-Reproduktionen sorgen mit einer besonderen Oberflächenstruktur für eine außergewöhnliche Haptik, so wie bei einem echten Furnier. Bei den Unis bieten altbewährte wie auch neue Modelle den angesagten Matt-Look mit funktionaler Anti-Fingerprint-Eigenschaft und samtweicher Softtouch-Oberfläche.

Experience surfaces

In a world that is noted for its digital influences, haptics are becoming increasingly important. New oak reproductions with a special surface structure are extraordinary to the touch, just like real veneers. In plain colours, both tried-and-tested and new models offer the trendy matt look with the functional anti-fingerprint property and a velvety SoftTouch surface.

Vivre les surfaces

Dans un monde structuré autour du numérique, le toucher gagne en importance. Grâce à leur structure exceptionnelle, les nouvelles reproductions chêne procurent les mêmes sensations que le plaqué véritable. Comme les anciens, les nouveaux modèles unis offrent le look mat tendance avec un revêtement fonctionnel anti-traces de doigts, ainsi qu'une texture veloutée et ultra-douce.

Oppervlakken (be-)leven

Tastbaarheid wordt steeds belangrijker in een wereld, die grotendeels bepaald wordt door digitale invloeden. Nieuwe eiken-decors zorgen door hun bijzondere oppervlaktestructuur voor een uitzonderlijke tastbare structuur die op echt fineer lijkt. Bij de effen oppervlakken zijn zowel de bekende beproefde modellen als de nieuwe modellen voorzien van de moderne matte look met functionele Anti-Fingerprint-eigenschap en fluweelzacht softtouch-oppervlak.



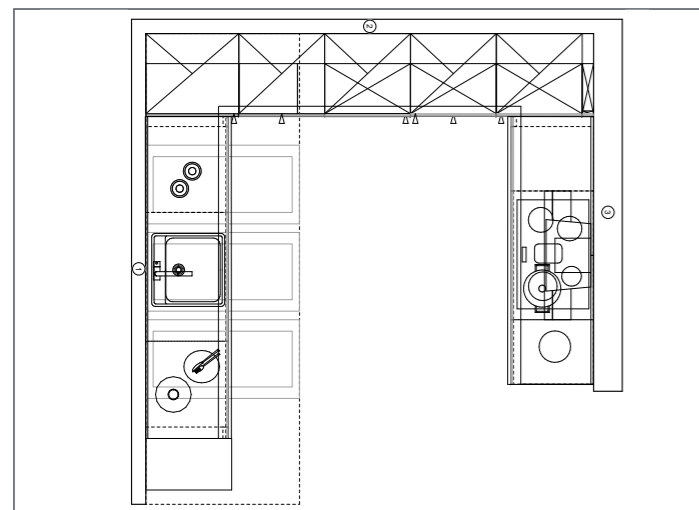

Kojen-Maße | Dimensions | Box | Kooi 3300 mm x 2150 mm

Griff | Handle | Poignée | Greep

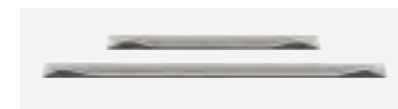

759

Korpus | Carcase | Corps | Corpus



109
Seidengrau
Silk grey
Gris soie
Zijdegrijs

Arbeitsplatte | Worktop | Plans de travail | Werkbladen



AP 824
Beton Opal
Concrete Opal
Béton opal
Beton opal

Fronten | Fronts | Façades | Fronten



SINUS
3000-247
Olive



QUADRO
2238
Beton Opal
Concrete Opal
Béton opal
Beton opal

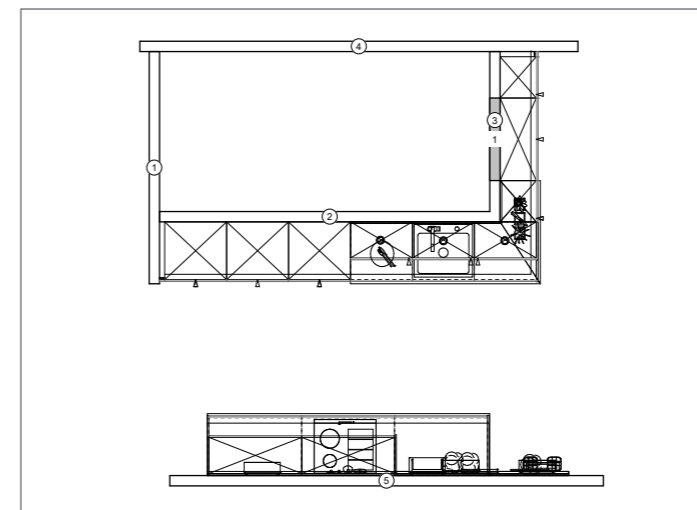

Kojen-Maße | Dimensions | Box | Kooi 5750 mm x 4400 mm

Griff | Handle | Poignée | Greep



710

Korpus | Carcase | Corps | Corpus



104
Kaschmir
Cashmere
Cachemire
Kasjmier

Fronten | Fronts | Façades | Fronten



LOFT
2225
Kaschmir
Cashmere
Cachemire
Kasjmier

Arbeitsplatte | Worktop | Plans de travail | Werkbladen



AP 863
Nussbaum
Walnut
Noyer
Noten

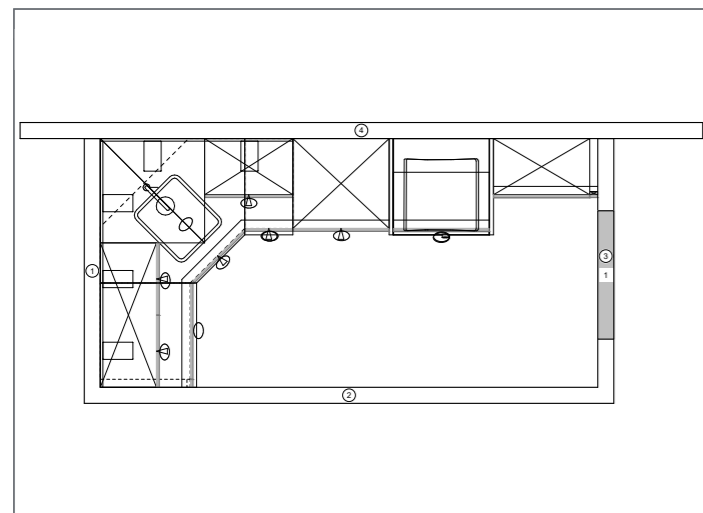

Kojen-Maße | Dimensions | Box | Kooi 3100 mm x 1550 mm

Griff | Handle | Poignée | Greep



474

Korpus | Carcase | Corps | Corpus



108
Schneeweiß
Snow white
Blanc neige
Sneuwit

Fronten | Fronts | Façades | Fronten



DELTA
2155
Schneeweiß
Snow white
Blanc neige
Sneuwit

COMO
2186
Fichte
Spruce
Epicéa
Vuren

Arbeitsplatte | Worktop | Plans de travail | Werkbladen

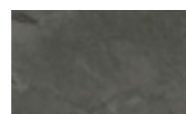

AP 869
Marmor Grau
Marble grey
Marbre gris
Marmer grijs

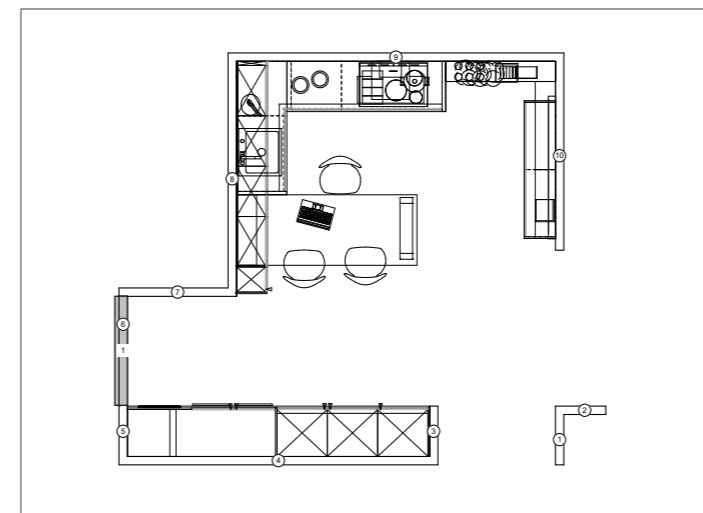

Kojen-Maße | Dimensions | Box | Kooi 5000 mm x 3800 mm

Griff | Handle | Poignée | Greep

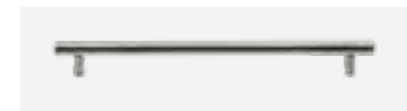

930

Korpus | Carcase | Corps | Corpus



124
Dust Grey

Fronten | Fronts | Façades | Fronten



COMO
2188
Verde

LOFT
2224
Dust Grey

Arbeitsplatte | Worktop | Plans de travail | Werkbladen



AP 810
Madera Natura

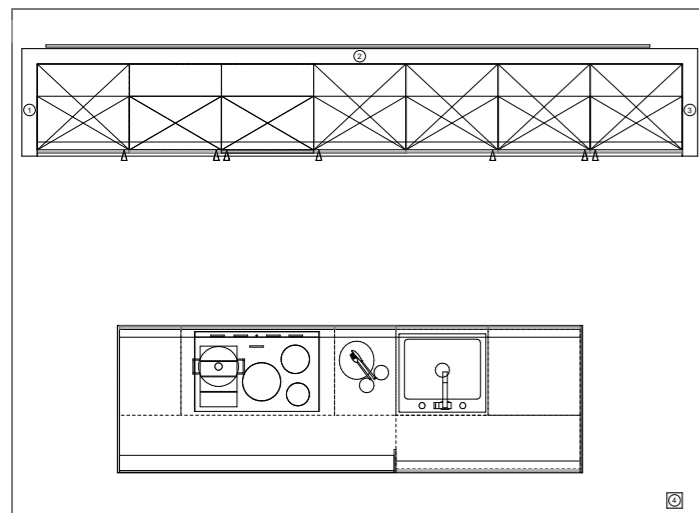

Kojen-Maße | Dimensions | Box | Kooi 4400 mm x 4000 mm

Griff | Handle | Poignée | Greep

PURE Schwarz (301) + Grifflos
 PURE Black (301) + handleless
 PURE Noir (301) + sans poignée
 PURE Zwart (301) + greeploos

Korpus | Carcase | Corps | Corpus



122
Dark Black

Arbeitsplatte | Worktop | Plans de travail | Werkbladen



Cosentino Dekton
 Liquid Embers
 (extern, external,
 externe, extern)

Fronten | Fronts | Façades | Fronten



FLORIDA Multicolour
 2100 · 4100-950
 RAL 330 20 15



WALLIS
 2700-322
 Hell
 Light
 Clair
 Licht

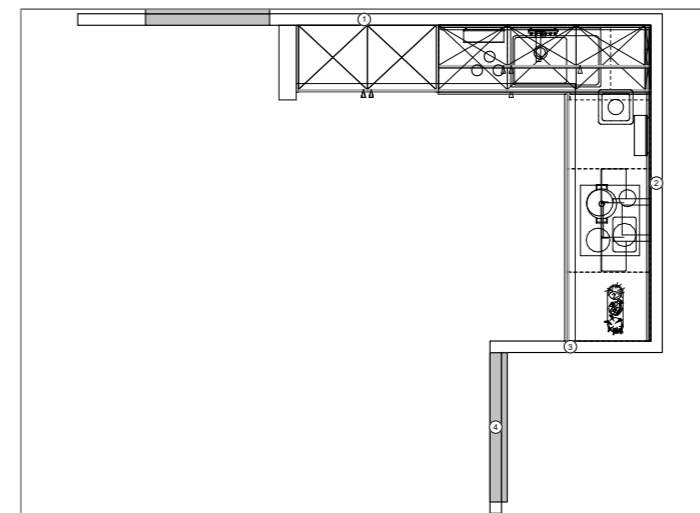

Kojen-Maße | Dimensions | Box | Kooi 3350 mm x 2750 mm

Griff | Handle | Poignée | Greep



890-02

Korpus | Carcase | Corps | Corpus



124
Dust Grey

Fronten | Fronts | Façades | Fronten



COMO
 2189
 Azzurro



COMO
 2187
 Ulme
 Elm
 Orme
 Olm

Arbeitsplatte | Worktop | Plans de travail | Werkbladen



AP 871
 Basalt Anthrazit
 Basalt anthracite
 Basalte anthracite
 Basalt antraciet

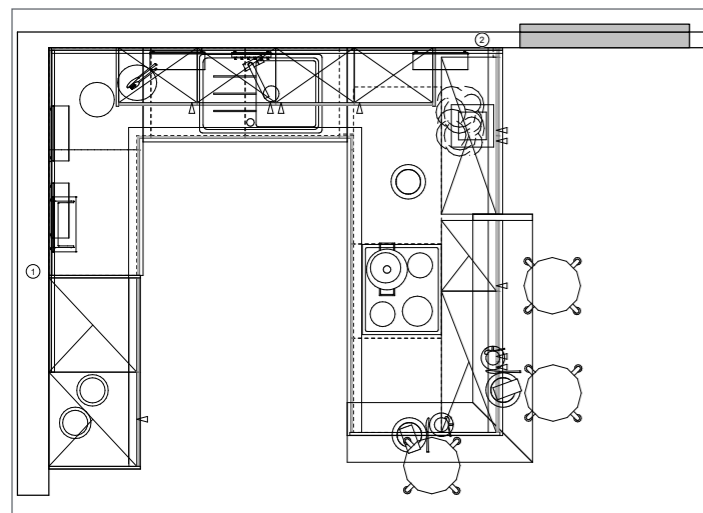

Kojen-Maße | Dimensions | Box | Kooi 3500 mm x 3000 mm

Griff | Handle | Poignée | Greep



720

Korpus | Carcase | Corps | Corpus



119
Golden Oak

124
Dust Grey

Fronten | Fronts | Façades | Fronten



MONTANA
2255
Golden Oak

SINUS
3000-9999
RAL 240 50 05

Arbeitsplatte | Worktop | Plans de travail | Werkbladen



AP 602
Eisengrau
Iron grey
Gris fonte
Ijzergrijs

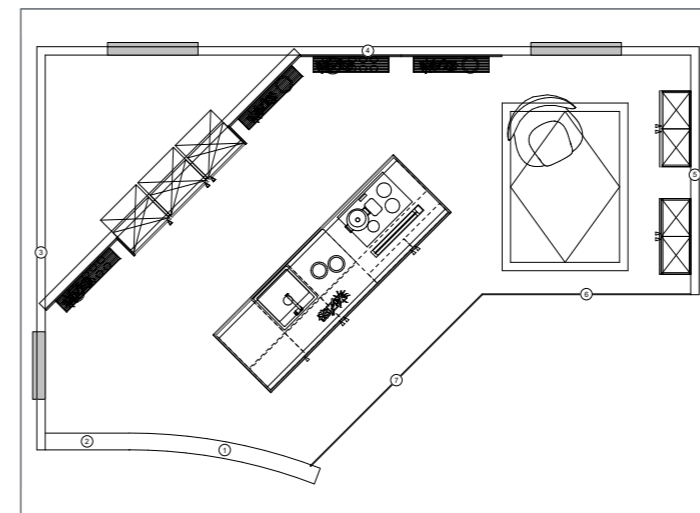

Kojen-Maße | Dimensions | Box | Kooi 7000 mm x 4300 mm

Griff | Handle | Poignée | Greep

PURE Schwarz (301) + Grifflos
PURE Black (301) + handleless
PURE Noir (301) + sans poignée
PURE Zwart (301) + greeploos

Korpus | Carcase | Corps | Corpus



122
Dark Black

Fronten | Fronts | Façades | Fronten



PORTO
2264
Piano Matt

PORTO
4262
Titanio Matt

PORTO
4263
Sabbia Matt

Arbeitsplatte | Worktop | Plans de travail | Werkbladen



AP 860
Fenix Nero

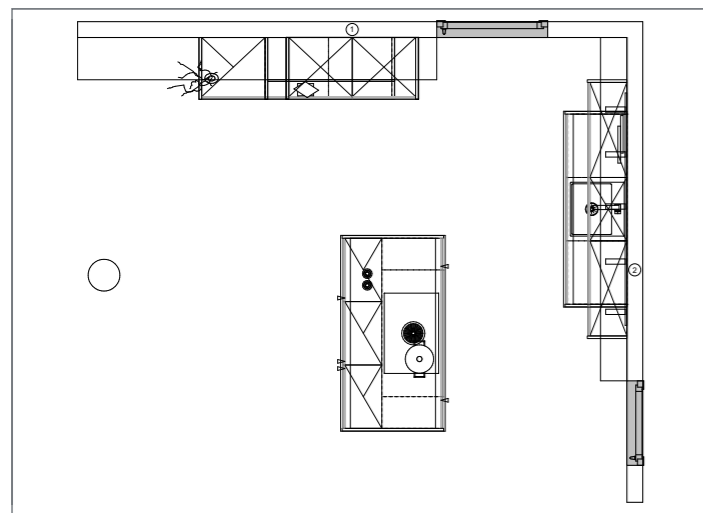

Kojen-Maße | Dimensions | Box | Kooi 4200 mm x 4250 mm

Griff | Handle | Poignée | Greep

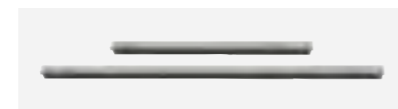

772

Korpus | Carcase | Corps | Corpus



123

Onyxgrau
Onyx grey
Gris onyx
Onyxgrijs

04

Weiß
White
Blanc
Wit

Arbeitsplatte | Worktop | Plans de travail | Werkbladen



AP 872

Chepe

PerfectSense®

Fronten | Fronts | Façades | Fronten



SENSE

2230
Weiß
White
Blanc
Wit

SINUS

3000-228
Stahlblau
Steel blue
Bleu acier
Staalblauw

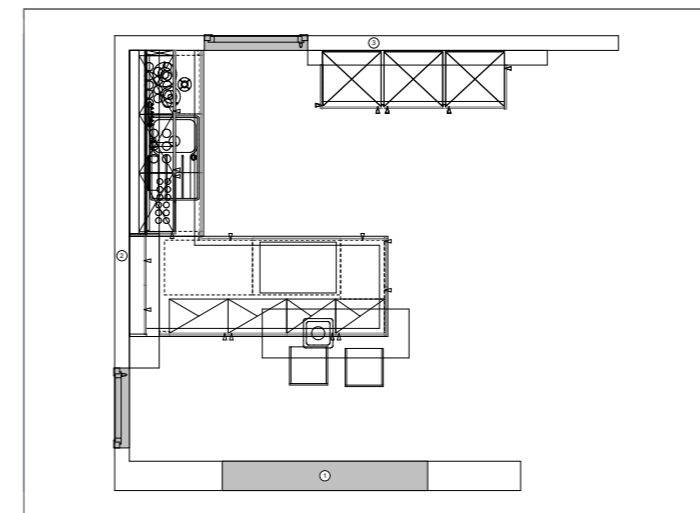

Kojen-Maße | Dimensions | Box | Kooi 4200 mm x 4000 mm

Griff | Handle | Poignée | Greep



778

+ PURE (NCS S 7500-N)

Korpus | Carcase | Corps | Corpus



123

Onyxgrau
Onyx grey
Gris onyx
Onyxgrijs

114

Cantaro Oak

Arbeitsplatte | Worktop | Plans de travail | Werkbladen



AP 873

Botticino

AP 814

Cantaro Oak

Fronten | Fronts | Façades | Fronten



PIEMONT

3460 · 4460-9999
NCS S 7500-N

DELTA

2152
Cantaro Oak

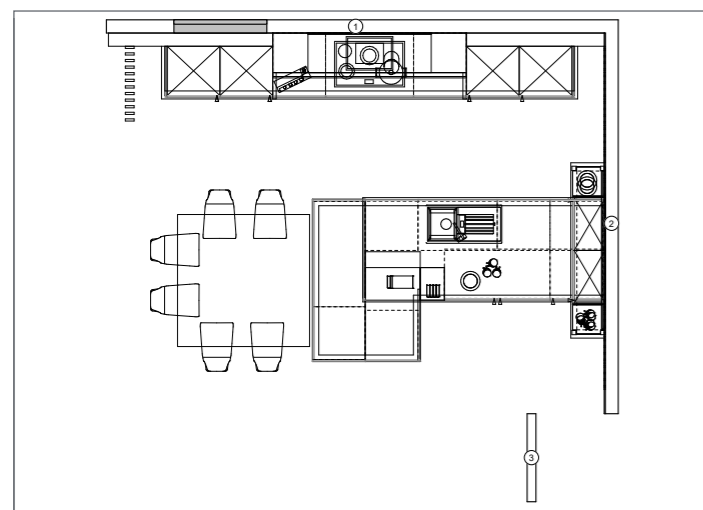

Kojen-Maße | Dimensions | Box | Kooi 5600 mm x 4350 mm

Griff | Handle | Poignée | Greep



385

Korpus | Carcase | Corps | Corpus

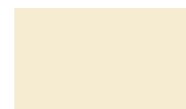

29
Magnolia

Fronten | Fronts | Façades | Fronten

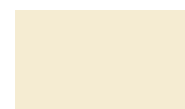

NORMANDIE
3470-79
Magnolia

Arbeitsplatte | Worktop | Plans de travail | Werkbladen



AP 709
Astoria Eiche
Astoria Oak
Chêne Astoria
Astoria eiken

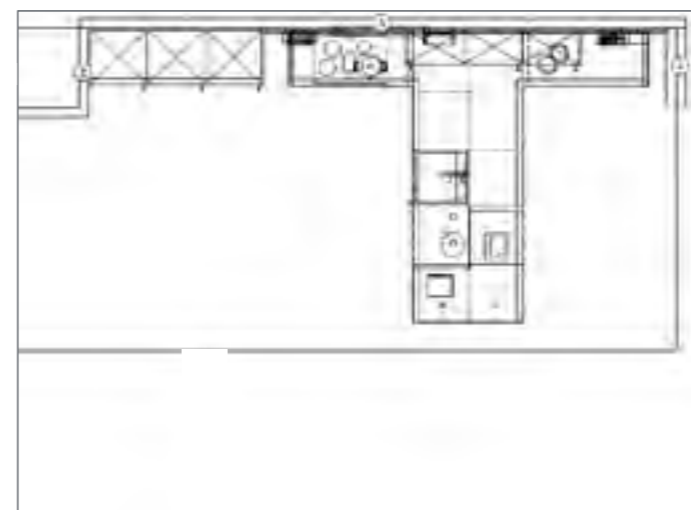

Kojen-Maße | Dimensions | Box | Kooi 6050 mm x 3550 mm

Griff | Handle | Poignée | Greep

PURE Schwarz (301) + Grifflos
PURE Black (301) + handleless
PURE Noir (301) + sans poignée
PURE Zwart (301) + greeploos

Korpus | Carcase | Corps | Corpus



122
Dark Black

Fronten | Fronts | Façades | Fronten



OXFORD
2336
Masteroak Fumed



SINUS
4000-249
Volcano

Arbeitsplatte | Worktop | Plans de travail | Werkbladen



AP 604
Schwarzgrau
Black grey
Gris noir
Zwartgrijs

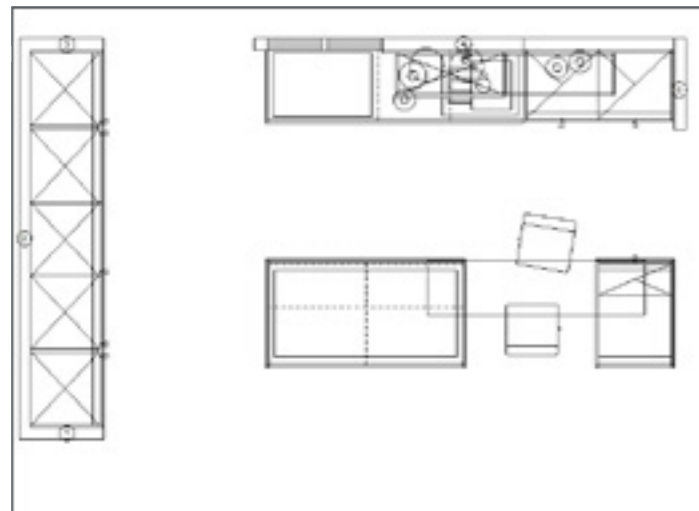

Kojen-Maße | Dimensions | Box | Kooi 5500 mm x 3200 mm

Griff | Handle | Poignée | Greep



PURE Weiß (302)
PURE White (302)
PURE Blanc (302)
PURE Wit (302)

453

Korpus | Carcase | Corps | Corpus

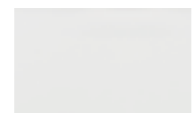

04
Weiß
White
Blanc
Wit

Fronten | Fronts | Façades | Fronten



AROSA
2295 · 4295
Fenix Bianco

Arbeitsplatte | Worktop | Plans de travail | Werkbladen

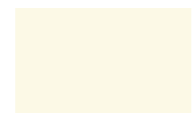

AP 861
Fenix Bianco



AP 852
Pietra Grigia



Kojen-Maße | Dimensions | Box | Kooi 5100 mm x 2500 mm

Griff | Handle | Poignée | Greep

PURE Fossil (508) + Grifflos
PURE Fossil (508) + handleless
PURE Fossil (508) + sans poignée
PURE Fossil (508) + greeploos

Korpus | Carcase | Corps | Corpus



123
Onyxgrau
Onyx grey
Gris onyx
Onyxgrijs

PerfectSense®

Fronten | Fronts | Façades | Fronten



SENSE
4233
Fossil



OXFORD
2337
Masteroak Brown

Arbeitsplatte | Worktop | Plans de travail | Werkbladen

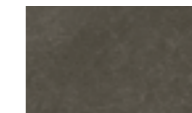

AP 875
Bellisara Dark





Kojen-Maße | Dimensions | Box | Kooi 3550 mm x 1500 mm

Griff | Handle | Poignée | Greep

Grifflos
handleless
sans poignée
greekploos

Korpus | Carcase | Corps | Corpus

- | | |
|---|--|
|  |  |
| 123
Onyxgrau
Onyx grey
Gris onyx
Onyxgrijs | 104
Kaschmir
Cashmere
Cachemire
Kasjmier |

Fronten | Fronts | Façades | Fronten

- | | |
|--|---|
|  |  |
| SINUS
3000-249
Volcano | SINUS
3000-248
Fossil |



Kojen-Maße | Dimensions | Box | Kooi 7000 mm x 3500 mm



Griff | Handle | Poignée | Greep

-  + PURE Edelstahlfarbig (E98)
+ PURE Stainless steel coloured (E98)
+ PURE Couleur inox (E98)
+ PURE Rvs-kleur (E98)
890-01

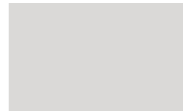
Korpus | Carcase | Corps | Corpus

- | | | |
|---|---|---|
|  |  |  |
| 109
Seidengrau
Silk grey
Gris soie
Zijdegrijs | 123
Onyxgrau
Onyx grey
Gris onyx
Onyxgrijs | 122
Dark Black |

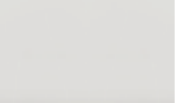
Fronten | Fronts | Façades | Fronten

- | | | |
|---|---|---|
|  |  |  |
| CALIFORNIA
Multicolour
2200-980
NCS S6020-R | CALAS
4387
Seidengrau
Silk grey
Gris soie
Zijdegrijs | NEW YORK
2630-700
Industrial Grey |

Arbeitsplatte | Worktop | Plans de travail | Werkbladen

- 
AP 848
Antique Oak

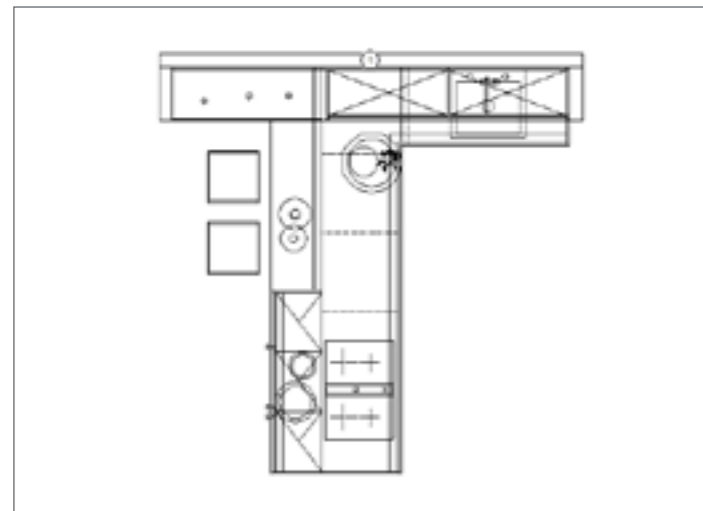

Kojen-Maße | Dimensions | Box | Kooi 5600 mm x 3300 mm

Griff | Handle | Poignée | Greep



773

Korpus | Carcase | Corps | Corpus



122
Dark Black

Arbeitsplatte | Worktop | Plans de travail | Werkbladen



AP 874
Bellisara Light



AP 871
Basalt Anthrazit
Basalt anthracite
Basalte anthracite
Basalt antraciet

PerfectSense®

Fronten | Fronts | Façades | Fronten



SENSE
2234
Graphite



COMO
2184
Eiche
Oak
Chêne
Eiken

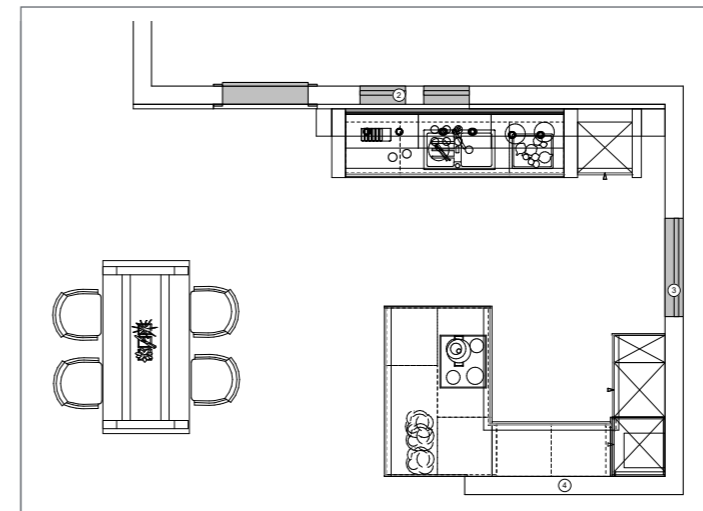

Kojen-Maße | Dimensions | Box | Kooi 4150 mm x 5850 mm

Griff | Handle | Poignée | Greep



508

Korpus | Carcase | Corps | Corpus

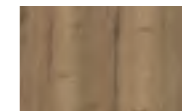

120
Chocolate Oak



122
Dark Black

Fronten | Fronts | Façades | Fronten

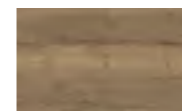

HAVANNA
2282
Chocolate Oak



LOFT
2223
Dark Black

Arbeitsplatte | Worktop | Plans de travail | Werkbladen



AP 604
Schwarzgrau
Black grey
Gris noir
Zwartgrijs

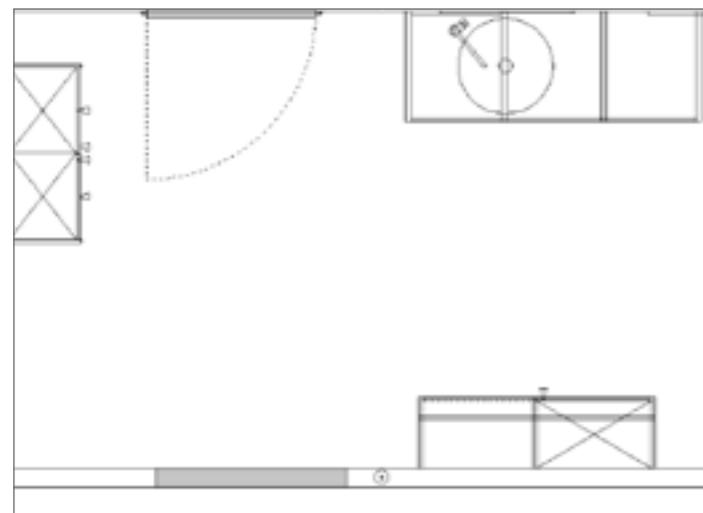

Kojen-Maße | Dimensions | Box | Kooi 2500 mm x 3500 mm

Griff | Handle | Poignée | Greep



218

- + Grifflos
- + handleless
- + sans poignée
- + greeploos

Korpus | Carcase | Corps | Corpus



124
Dust Grey

Fronten | Fronts | Façades | Fronten



WALLIS
2700-321
Natur
Nature
Nature
Natuur



SINUS
3000-246
Dust Grey



BERN
2800-321
Natur
Nature
Nature
Natuur

Arbeitsplatte | Worktop | Plans de travail | Werkbladen



AP 866
Beton Schwarz
Concrete black
Béton noir
Beton zwart

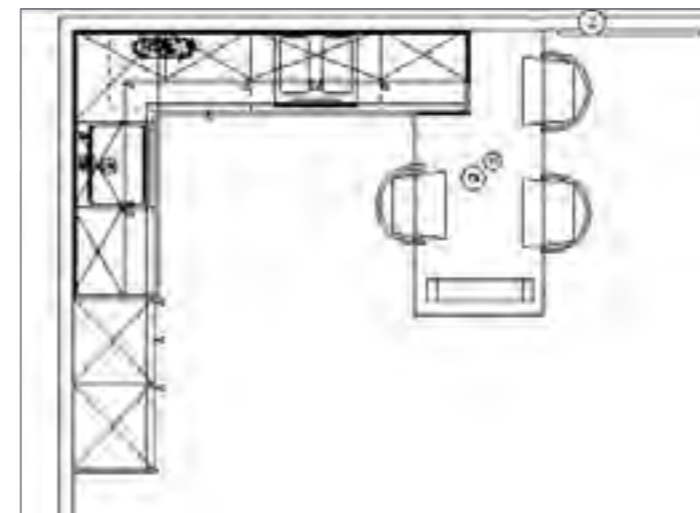

Kojen-Maße | Dimensions | Box | Kooi 3100 mm x 3750 mm

Griff | Handle | Poignée | Greep



406

Korpus | Carcase | Corps | Corpus

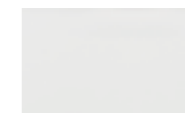

04
Weiß
White
Blanc
Wit

Fronten | Fronts | Façades | Fronten



CRISTAL
2444
Weiß
White
Blanc
Wit



AROSA
2296
Fenix Grigio Londra

Arbeitsplatte | Worktop | Plans de travail | Werkbladen

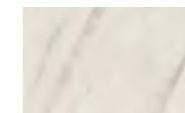

AP 876
Levanto



Kojen-Maße | Dimensions | Box | Kooi 3500 mm x 3750 mm

Griff | Handle | Poignée | Greep



720

Korpus | Carcase | Corps | Corpus



124
Dust Grey

123
Onyxgrau
Onyx grey
Gris onyx
Onyxgrijs

Fronten | Fronts | Façades | Fronten



COMO
2185
Nussbaum
Walnut
Noyer
Noten

PORTO
2266
Graphite Matt

Arbeitsplatte | Worktop | Plans de travail | Werkbladen



AP 863
Nussbaum
Walnut
Noyer
Noten

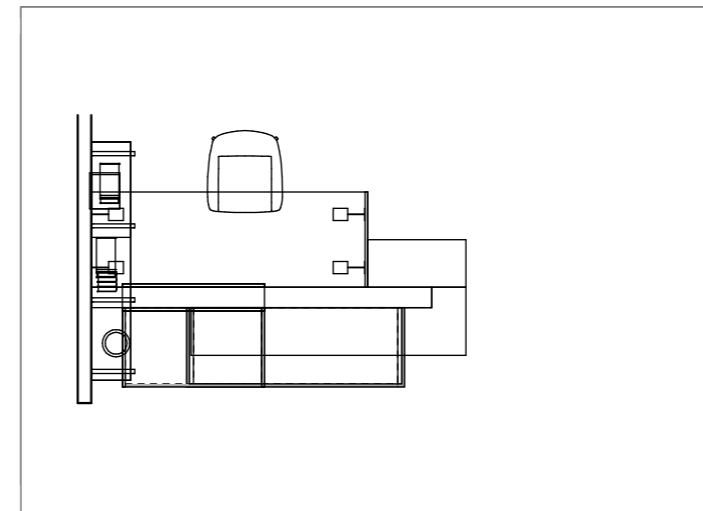
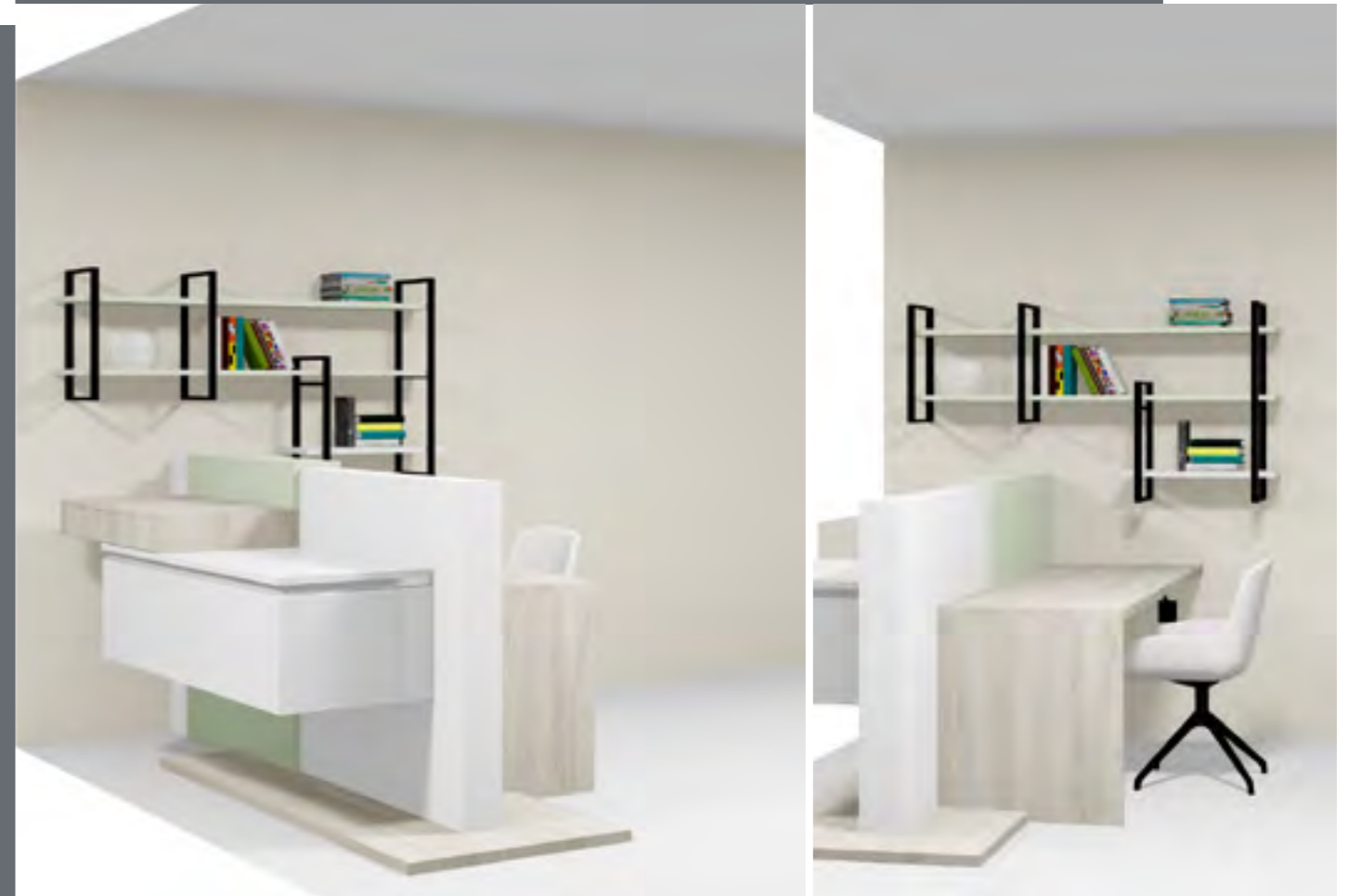

Kojen-Maße | Dimensions | Box | Kooi 2150 mm x 2750 mm

Griff | Handle | Poignée | Greep

PURE Edelstahlfarbig (E98) + Grifflos
PURE Stainless steel coloured (E98) + handleless
PURE Couleur inox (E98) + sans poignée
PURE Rvs-kleur (E98) + greeploos

Korpus | Carcase | Corps | Corpus



109
Seidengrau
Silky grey
Gris soie
Zijdegrijs

Fronten | Fronts | Façades | Fronten



FRESH
4316
Seidengrau
Silky grey
Gris soie
Zijdegrijs

COMO
2187
Ulme
Elm
Orme
Olm

Arbeitsplatte | Worktop | Plans de travail | Werkbladen



AP 865
Ulme
Elm
Orme
Olm

HIGHLIGHTS

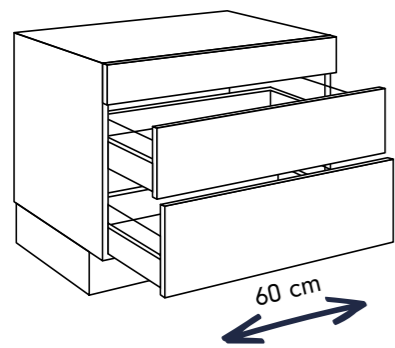

Muldenlüfter-Unterschränke 600 mm Breite

in allen bekannten
Schrankausführungen

Table extractor base units 600 mm wide

in all the known
cabinet designs

Meubles bas pour aérateur intégré 600 mm de large

dans toutes les
finitions connues

Onderkasten voor werkbladafzuiging 600 mm breed

in alle bekende
kastuitvoeringen

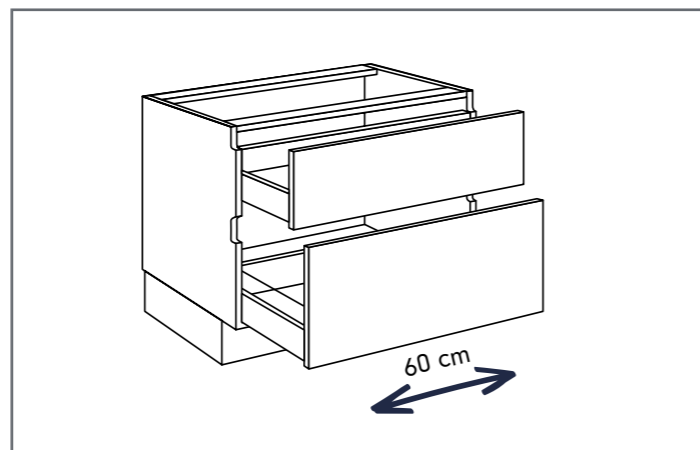

PURE-Spülunterschränke 600 mm Breite

mit 2 Frontauszügen

PURE sink base units 600 mm wide

with 2 front pull-outs

Meubles bas sous-évier PURE 600 mm de large

avec 2 coulissants

PURE-spoelkasten 600 mm breed

met 2 uittrekfronten

HIGHLIGHTS



Oberschränke für integrierte Designhauben

in 600 und 900 mm Breite

für alle bestehenden Flachhauben-
Schranktypen

Wall units for integrated design hoods

600 and 900 mm wide

for all existing flat-hood cabinet
types

Meubles hauts pour hottes design intégrées

en 600 et en 900 mm de large

Pour tous les modèles d'hottes
plates

Bovenkasten voor geïntegreerde design-afzuigkappen

in 600 en 900 mm breed

voor alle bestaande kastmodellen
voor platte afzuigkappen



Aktualisierung Konsolen und Stützfüße in eckiger Form

In Schwarz
In Edelstahlfarbig

Update consoles and square support feet

In black
In stainless-steel colour

Actualisation consoles et pieds d'appui carrés

Noir
Couleur inox

Actualisering consoles en steunpoten met hoekige vorm

In zwart
In rvs-kleur



Unterschränke 350 mm Tiefe

in allen Schrankbreiten
300 bis 1200 mm

mit Tür/Schubkasten/Frontauszug
ohne Mehrpreis

Base units 350 mm deep

in all cabinet widths
300 to 1200 mm

with door / drawer / front pull-out
at no extra cost

Meubles bas 350 mm de profondeur

dans toutes les largeurs
de 300 à 1200 mm

avec porte/tiroir/coulissant
sans supplément de prix

Onderkasten 350 mm diep

in alle kastbreedtes
300 tot 1200 mm

met deur/lade/uittrekelement
zonder meerprijs

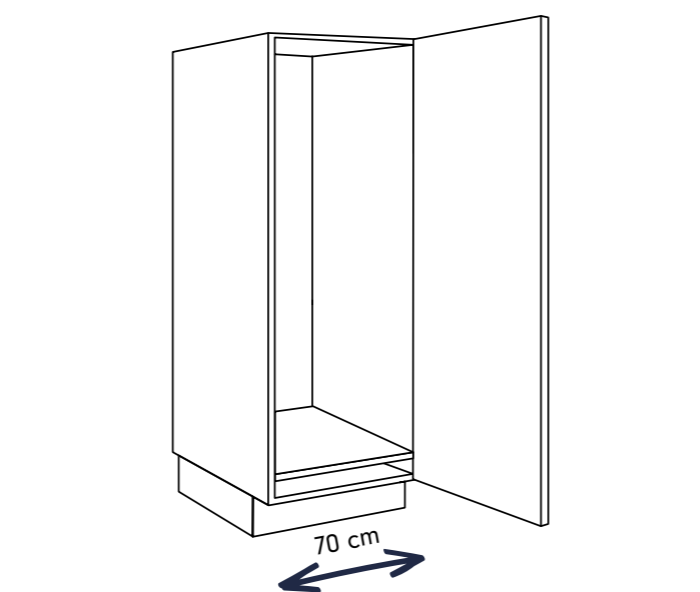

Hochschränke für 70er Kühlgeräte

in allen schneidbaren Fronten

Tall units for refrigerators/ freezers 70 cm

in all reducible fronts

Armoires pour réfrigérateurs en 70 cm de large

dans toutes les façades à recouper

Hoge kasten voor 70 cm brede koelkasten

in alle bewerkbare fronten



Vorratsschränke mit Frontauszug

mit zusätzlicher Dämpfung beim
Öffnen

in allen Schrankhöhen
auch zum Nachrüsten

Larder units with front pull-out

with additional cushioning when
opening

in all cabinet heights
also for retrofitting

Armoires à provisions avec coulissant

avec amortissement supplémen-
taire à l'ouverture

dans toutes les hauteurs
également pour installation
ultérieure

Vorraadkasten met uittrekfront

met extra demping bij het
openen

in alle kashoogtes
ook om achteraf te monteren



Aktualisierung Wandabschlussprofile

In Schwarz
In Edelstahlfarbig

Update upstands

In black
In stainless-steel colour

Actualisation profils de finition murale

Noir
Couleur inox

Actualisering wandprofielen

In zwart
In rvs-kleur

open living

Leben, wohnen und arbeiten - Ein perfektes Trio

Wohnkonzepte gehen fließend ineinander über und bieten grenzenlose Möglichkeiten. Werkstoffe mit verschiedensten Oberflächen und Strukturen, Farben und Formen oder auch offene und geschlossene Flächen treffen kontrastierend aufeinander und setzen sich gegenseitig in Szene.

Kombinationsmöglichkeiten und persönlicher Geschmack bestimmen den Lifestyle von heute, um eine individuelle Küche zu schaffen. Raum-in-Raum-Planungen, aber auch Regale oder Sideboards können dabei sowohl als Bindeglied als auch als Solisten agieren.

Life, living and working - the perfect trio

Living concepts flow smoothly into each other, and offer endless possibilities. Materials with the most diverse surfaces and textures, colour and shapes, or open and closed surfaces meet in contrast with, and set the scene for each other.

Combination options and personal taste determine today's lifestyle when creating an individual kitchen. Room-in-room designs, shelves and sideboards can serve both as a link and as soloists.

Vivre, habiter et travailler - Un trio imbattable

Les frontières entre les différentes pièces s'estompent et ouvrent de nouvelles perspectives. Les matériaux aux surfaces et structures variées, les couleurs et les formes ou les éléments ouverts et fermés contrastent tout en se subliment mutuellement.

Les combinaisons et les goûts de chacun déterminent le mode de vie d'aujourd'hui pour personnaliser la cuisine. Les planifications « deux pièces dans une », les étagères ou les buffets peuvent alors être le maillon entre les différentes zones ou convaincre en solistes.

Leven, wonen en werken - een perfect trio

Woonconcepten lopen vloeiend in elkaar over en bieden eindeloze mogelijkheden. Materialen met de meest uiteenlopende oppervlakken en structuren, kleuren en vormen, maar ook open en gesloten oppervlakken komen als contrast bij elkaar en zorgen ervoor dat ze door hun contrast elkaar in de schijnwerpers zetten.

De lifestyle van tegenwoordig wordt bepaald door combinatiemogelijkheden en persoonlijke smaak, zodat er een individuele keuken kan ontstaan. Ruimte-in-ruimte-ontwerpen, maar ook schappen of dressoirs kunnen hierbij een verbindend element zijn, maar ook als solist worden gebruikt.

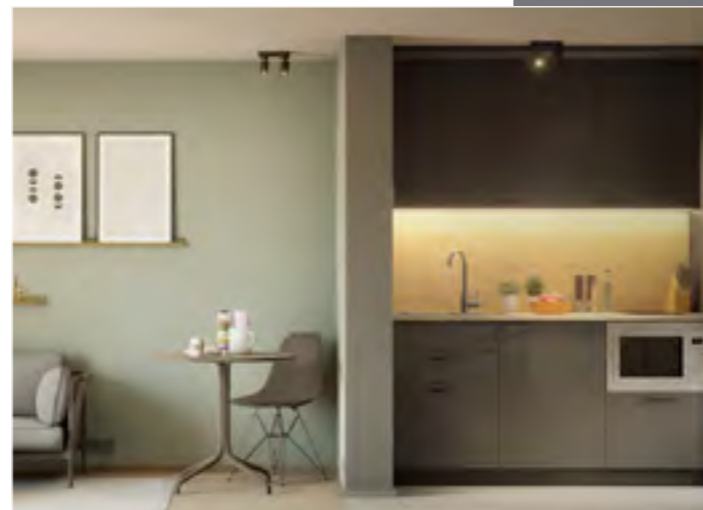

modern spaces

modern work



Intelligente, funktionale Module oder raumteilende Solitäre dienen der Gliederung unterschiedlicher Wohnzonen und unterstreichen das wohnliche Ambiente. Alle Komponenten tragen im Zusammenspiel dazu bei, den Wohnraum zu einem Ort zu machen, der Persönlichkeit und Stil widerspiegelt.

Intelligent, functional furniture or room-dividing stand-alones serve to the various different living zones and underline the homely ambience. The components all work together to make the living space a place that reflects personality and style.

modern life



Les modules judicieux et fonctionnels ou les solitaires en guise de cloison permettent de délimiter les espaces de vie et de souligner l'ambiance chaleureuse. Tout contribue à créer un intérieur qui reflète le style et la personnalité de chacun.

Intelligente, functionele modules of ruimte-indelende losstaande kasten dienen om de verschillende woonzones in te delen en de huiselijke sfeer te benadrukken. Alle componenten zorgen er samen voor dat de woonkamer een plek wordt, waarin de persoonlijkheid en eigen stijl worden weerspiegeld.



COLOUR CONCEPT

CREATIVE VERSATILITY FOR EVERY LIFESTYLE!

Struktursamtlack
Textured velvet lacquer
Laqué velours structuré
Gestructureerde fluweellak

SINUS



PIEMONTE



NORMANDIE



AUSLAUF | DISCONTINUATION | FINS DE SÈRIE | UITLOOP

FRONTEN FRONTS FAÇADES FRONTEN

DELTA



2153 · 4153
Pearl



2142 · 4142
Trüffelgrau
Truffle grey
Gris truffe
Truffelgrijs

FRESH



2315 · 4315
Onyxgrau
Onyx grey
Gris onyx
Onyxgrijs

SAN REMO

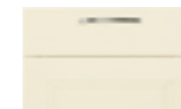

2423
Magnolia

TORINO



3450-



ARBEITSPLATTEN WORKTOPS PLANS DE TRAVAIL WERKBLADEN

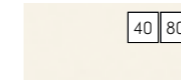

AP 870
Weiß
White
Blanc
Wit

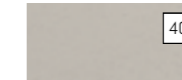

AP 834
Kaschmir
Cashmere
Cachemire
Kasjmier



AP 836
Onyxgrau
Onyx grey
Gris onyx
Onyxgrijs

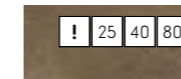

AP 854
Arenito



AP 846
Patina

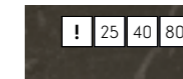

AP 855
Vulcano Grey

KORPUSDEKORE CARCASS DECORS DÉCORS CORPS CORPUS DECORS



115
Pearl



112
Trüffelgrau
Truffle grey
Gris truffe
Truffelgrijs

STRUKTURSAMLACK TEXTURED VELVET LACQUER LAQUÉ VELOURS STRUCTURÉ GESTRUCTUREERDE FLUWEELLAK



233
Pearl



219
Trüffelgrau
Truffle grey
Gris truffe
Truffelgrijs



239
Chili



244
Cherry Red



243
Sky Blue



227
Manhattan

Matt & Hochglanzlack
Matt & high gloss laquer
Mat & laqué brillant
Mat & hoogglanslak

FLORIDA MULTICOLOUR



CALIFORNIA MULTICOLOUR



Das Brigitte **COLOUR CONCEPT** ermöglicht neben zahlreichen Grundfarben zusätzlich alle RAL/NCS-Farbtöne. Das erlaubt ganz neue, mutige und innovative Farbexperimente.

- 4500 Farbmöglichkeiten in RAL/NCS
- 5 unterschiedliche Programme
- 3 verschiedene ECHT-Lackarten

In addition to a huge range of base colours, the Brigitte **COLOUR CONCEPT** also enables all RAL/NCS colour shades. This allows for completely new, bold and innovative colour experiments.

- 4500 RAL/NCS colour options
- 5 different ranges
- 3 different TRUE lacquer types

Le **COLOUR CONCEPT** de Brigitte Küchen permet d'obtenir, outre de nombreux coloris de base, également tous les coloris en RAL/NCS. Cela permet d'expérimenter des coloris nouveaux, audacieux et innovants.

- 4500 coloris en RAL/NCS
- 5 programmes différents
- 3 types de laque VÉRITABLE

Het Brigitte **COLOUR CONCEPT** maakt naast talrijke basiskleuren ook alle RAL/NCS-kleuren mogelijk. Hierdoor zijn geheel nieuwe, gedurfde en innovatieve kleurexperimenten mogelijk.

- 4500 kleurmogelijkheden in RAL/NCS
- 5 verschillende programma's
- 3 verschillende soorten ECHTE lak



Letzter Termin für Neu- bzw. Ergänzungsbestellungen von Auslaufmodellen ist der 31.03.2024 mit spätester Auslieferung bis 30.06.2024.

Danach bitte Rücksprache mit unserem Serviceteam nehmen. Neue Schranktypen sind für Auslaufmodelle nicht lieferbar.

The deadline for new or supplementary orders for discontinued models is 31/03/2024, and delivery up to 30/06/2024 at the latest.

After this date, please talk to your service team. New cupboard types are not available on discontinued models.

Dernier délai des commandes nouvelles ou complémentaires pour les modèles de fin de série 31/03/2024 avec une livraison au plus tard le 30/06/2024.

Passée cette date, veuillez vous adresser à votre équipe de service. Les nouveaux types d'armoires ne sont pas disponibles pour les modèles de fin de série.

Nieuwe of aanvullende bestellingen voor uitlopende modellen kunnen tot 31-03-2024 worden geplaatst met laatste leverdatum tot 30-06-2024.

Hierna kunt u overleggen met het serviceteam. Nieuwe kasttypen zijn niet leverbaar voor uitlopende modellen.

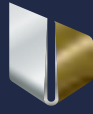

german
brand
award
17
gold

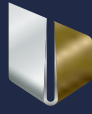

german
brand
award
18



german
brand
award
21
special



german
brand
award
22
winner



www.britte-kuechen.de

VKU-684-2309
Es ist nicht gestattet, den Katalog oder Teile daraus, ohne unsere schriftliche Genehmigung, in irgendeiner Form zu vervielfältigen.
Technische Änderungen vorbehalten. Keine Gewährleistung für Druckfehler oder Irrtümer. Farbabweichungen vorbehalten.
We reserve all rights to this catalogue under copyright law. It shall not be permitted to duplicate this catalogue in any form, either in whole or in part, without our prior written consent. Subject to technical alterations. Errata and misprints excepted. Subject to colour variations.
Nous nous réservons tous les droits sur ce catalogue. Il est strictement interdit de changer en partie ou totalement ce catalogue sans une autorisation écrite de notre part, ni de le dupliquer. Sous réserve de changements ou déviations techniques ou erreur d'impression.
Het is niet toegestaan om de catalogus of delen daarvan zonder onze schriftelijke toestemming op welke manier dan ook te verspreiden.
Technische wijzigingen voorbehouden. Geen aansprakelijkheid voor drukfouten of vergissingen. Kleurafwijkingen voorbehouden.

